

# User Manual

Home Mobile Signal Booster

Ace 5S

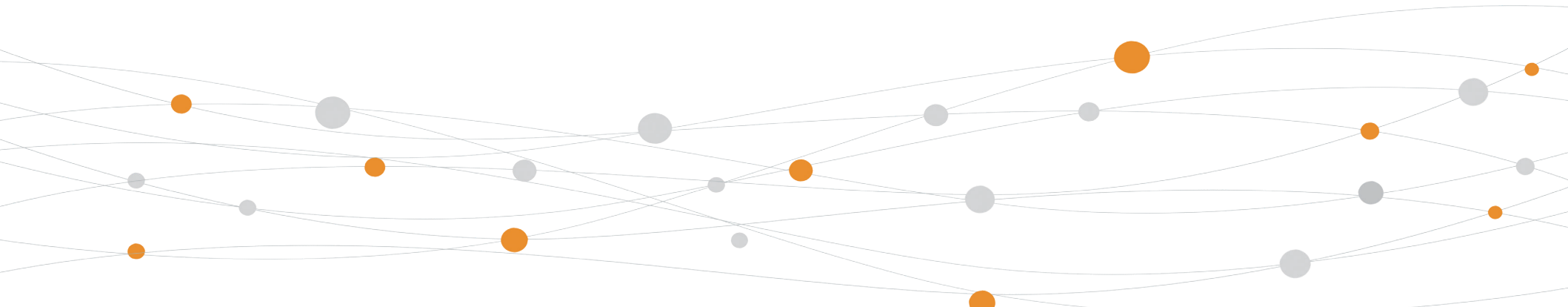

(972) 870-5666  
service@zorida.com

# CONTENTS

Package Content .....	01
Introduction .....	02
Pre-Installation Instructions .....	02
LED Indicator Lights .....	07
APP Assisted Installation .....	08
Quick Troubleshooting Guide .....	20
Technical Specifications .....	22
Authorized Accessories List .....	23
FCC and IC Statements .....	24
Return and Warranty Policies .....	26

# Zorida Ace 5S



Outdoor Antenna



49.2ft SMAM-SMAM Outdoor Cable



Booster



Indoor Whip Antenna



Power Supply



Accessories for main parts  
are all provided

Warning: Un-authorized antennas, cables, and/or coupling devices are prohibited by new FCC rules, Please contact FCC for details: 1(888)-CALL-FCC.

## Introduction

Thanks again for purchasing Zorida cell phone Booster. The Ace 5S is a collection of precision-engineered products that improve cellular reception inside of homes and businesses by amplifying incoming and outgoing cell phone signals.

The exclusive cloud-based signal monitoring mobile application of the Zorida cell booster allows users to remotely monitor the real-time status of Zorida cell phone signal boosters anytime, anywhere directly through their mobile devices.

If there are any issues while installing a Zorida Ace 5S cell phone signal booster, please contact the Zorida technical support team through the following options:

**Online Support:** Create a ticket or chat via Signal Supervisor App

☎ (972) 870-5666 (M-F from 9 am – 5 pm CST)

✉ [service@zorida.com](mailto:service@zorida.com)

## Pre-Installation Instructions

We strongly recommend you to read the user guide completely before you install. Zorida 5S booster provides App assisted installation.

1.App Assisted Installation:

**From Page 08~19.**

It's more convenient and many work could be done by ONE person, and the most important is that the obtained signal can be very precise.



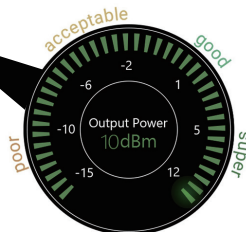

The app helps you find the best signal outside





## Then why has Zorida spent extra big efforts and costs to design APP and LCD signal meters to help you install?

Out of the various reasons, the most important reason is that we would like you, our valuable client, to get the maximum output power from the booster system in order to get optimal signal reception for all your mobile devices.

 As it is known and a big thanks, FCC makes signal boosters legal in 2014 so that every body can install and benefit from the signals;

 But FCC regulations do limit the gain and output power of all consumer boosters to low values in order to avoid any interference to the cell towers;

 Furthermore FCC stipulates that any improper install should trigger immediately further reduction of the booster's already-limited gain and power to protect the towers.

 Therefore, you can understand how important you need to find the perfect outside signal from the tower and how important to squeeze every last gain and power from the booster, even 1dB more power is so precious when you suffer from no signals.

## General Working Principle:

Before we start any of the two ways, please allow us to spend 3 pages to make you understand how the booster system works for you.

※ Please do spend some time to read it fully, as it is crucial to get full bars for your rooms.

## How Zorida booster works

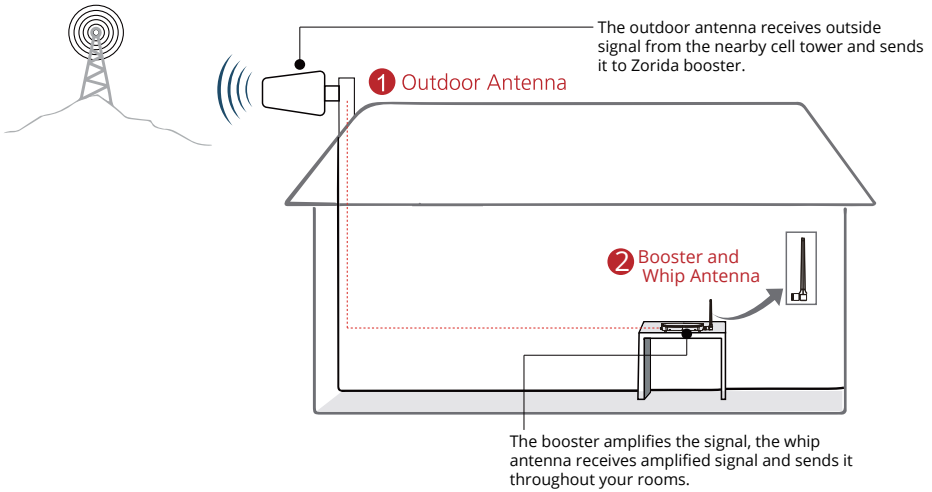

Vice versa, inside antenna receives phone signal and sends to the booster,  
The booster then amplifies and sends it to outside antenna,  
Outside antenna sends signal to the cell tower.  
Then you can make phone calls and do internet streaming.

## Working Principle in Formula

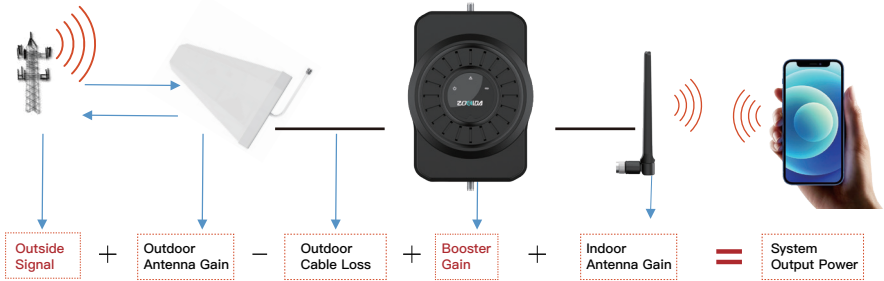

Out of the Formula:

**Outside Signal:** To be received by outdoor antenna from cell tower

**Outdoor Antenna Gain:** The gain of outdoor antenna

**Outdoor Cable Loss:** The loss of the outdoor cable

**Booster Gain:** The actual working gain of the booster

**Indoor Antenna Gain:** The gain of indoor antenna

### For example:

**-65dBm + 11dBi - 4.5dB + 60dB + 2dBi = 3.5dBm (System Output Power)**

Since the figures in **Black** color are fixed when you finish the purchase, thus the **RED** figures of

**1. Outside Signal**

**2. Booster Gain** will play a vital role in reaching the best output power during the installation, especially when we know the FCC limits the booster system values.

So the user guide is focused on:

1. Getting the best outside signal.
2. Keeping the maximum booster gain.

## More notes on how to keep the maximum booster gain

The self-oscillation from the outdoor antenna to the indoor antenna will reduce the gain, so the principle to keep the maximum booster gain is to avoid the self-oscillation from the outdoor antenna to the indoor antenna.

1) Increase the distance between the outdoor and indoor antenna, generally the same vertical distance generates more loss than horizontal, and to follow easily, a Typical Required Distance Between Outdoor and Indoor Antenna Over 30 feet (10 meters) straight line distance.

2) Use barriers between the indoor and outdoor antenna.

※ Please note: This separation is not an absolute mandate. The idea is to isolate the outdoor antenna from the indoor antenna.

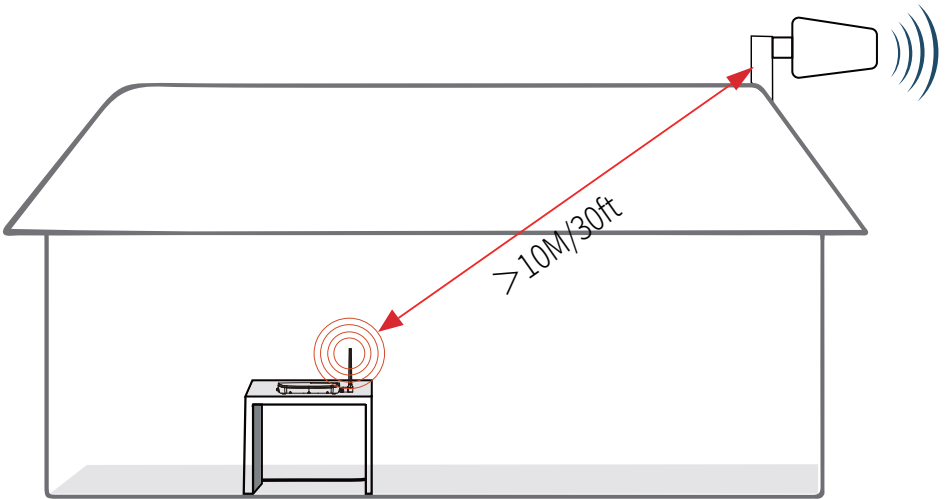



## LED Indicator Lights



Indicator light	input condition	output status
Alarm(ISO)	normal	blue light always on
	ISO=1 ~ 14dB	blue light flashes for 3 seconds
	ISO=15 ~ 21dB	blue light flashes for 1 second
	ISO≥22 dB	red light flashes for 1S
Power	normal	blue light is always on
	power off	Light off
Bluetooth	not connected	Blue light is always on
	connected	blue light flashes at 3S intervals

## Bands contained in the Gauges on Signal Supervisor

Gauge	Band	Uplink	Downlink
LTE700	12/17	698-716MHz	728-746MHz
	13	776-787MHz	746-757MHz
CELL800	5	824-849MHz	869-894MHz
PCSI900	2/25	1850-1910MHz	1830-1990MHz
AWS2100	4	1710-1755MHz	2110-2155MHz

Please focus on the gauge that contains the band you are using.

# App Assisted Installation

## Flow Chart of App Assisted Installation

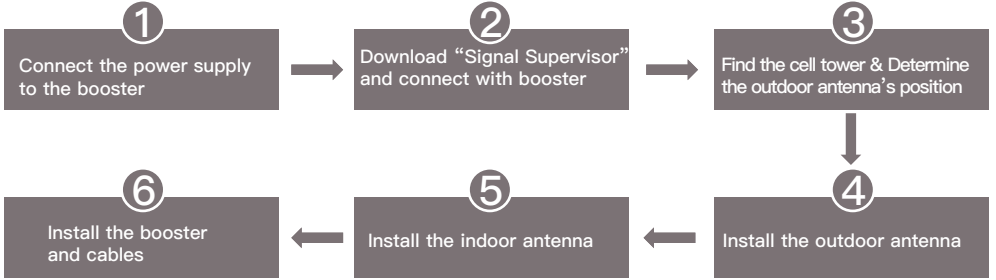

### Step 1: Connect the Power Supply to the Booster



Power Supply



Signal Booster

## Step 2: Download Signal Supervisor app and connect the booster

Download the Signal Supervisor app, register ID and booster.



- 1) Search "Signal Supervisor" on Google Play/ App Store, or scan the above QR Code to download.
  - 2) Register on the Signal Supervisor app.
  - 3) Plug in the booster
- \* As the device is equipped with a built-in Bluetooth antenna, there is no need to connect outdoor or indoor antennas at this moment.
- 4) Click "Add Device" to register the booster into the app.

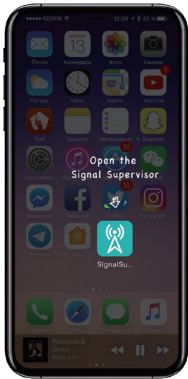

1

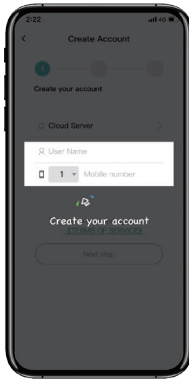

2

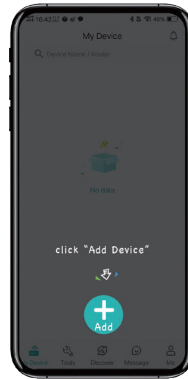

3



4

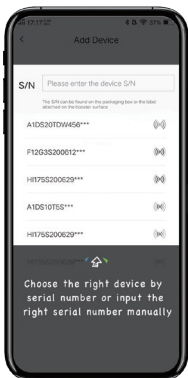

5

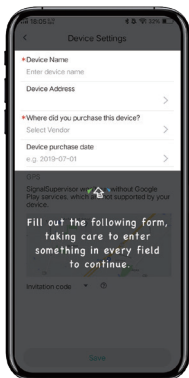

6

Please contact our tech support if you have difficulties in installation, and we will provide the best solution for you.

### Step 3: Find the cell tower & Determine the outdoor antenna's position

#### 3.1 Find the band you are using

For Android

Download NetWork Cell Info Lite in the Google store and open it.

It can be seen from the example picture that the frequency band is band 13.

(According to the form before, you need to pay attention to Gauge LTE700)

Then click MAP. You can see your phone connecting to a tower, and you can try aiming your outdoor antenna at it. But sometimes this is not accurate. You could also move to Step 3.2 to find the tower

Note: Please take screenshots at this stage.



For ios

(1)Dial \*3001#12345#\*

(2)Follow the instructions, take the screenshot as required.

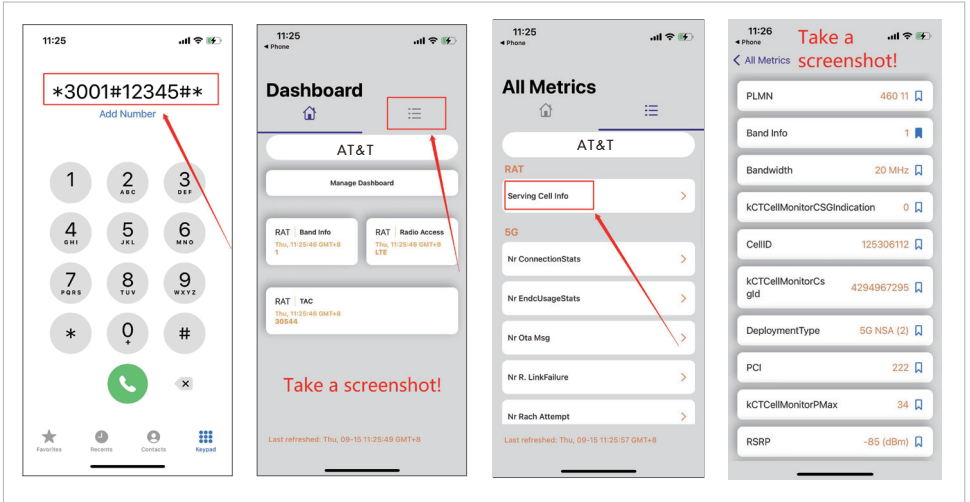

### 3.2 Find the cell tower

- (1) Enter cellmapper.net
- (2) Choose your own carrier and band here.

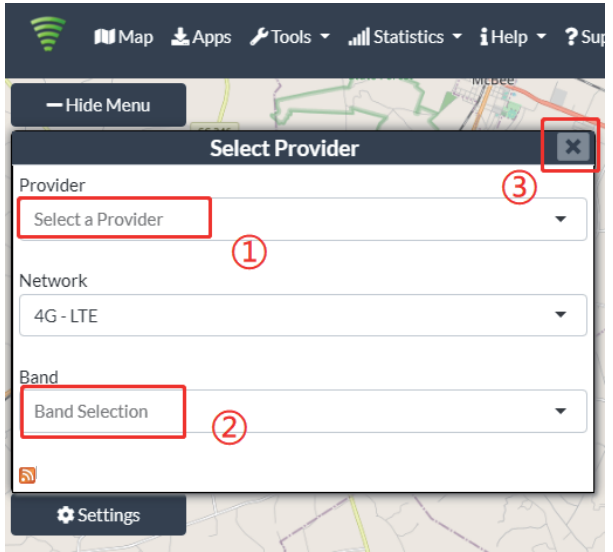
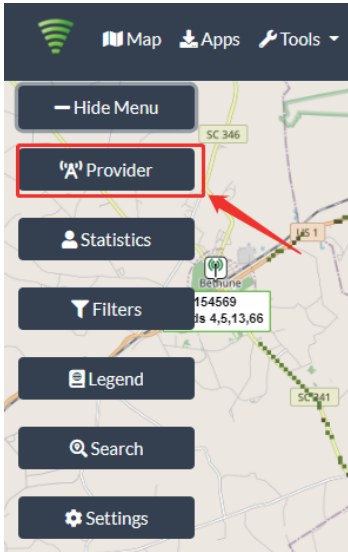

(3) Then enter the coordinate of where you are trying to install the signal booster, and press Enter key.

(In fact when you open Cellmapper, the map on the right will automatically locate your area if you've given the site permission to access your location.

If you found tower sites not even displayed on the map, it might be because the app intercepts the locations for security reasons.)

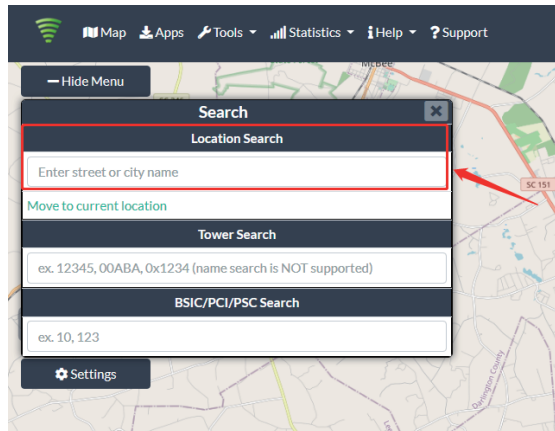
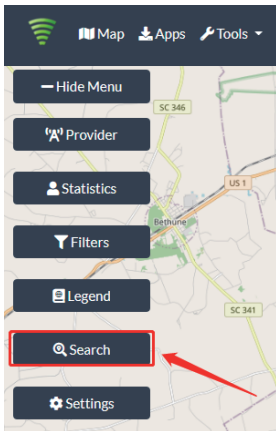

(4) After the map jumps to the location, you can scroll the mouse pulley and zoom it out, then you will see the tower near the location. It would be better to take a screenshot of this page to guide the following installation steps.

Should you have any questions, please contact our tech support.

Note: If you need help finding the tower, please contact our tech support and provide your carrier, band and screenshots taken in the last steps.

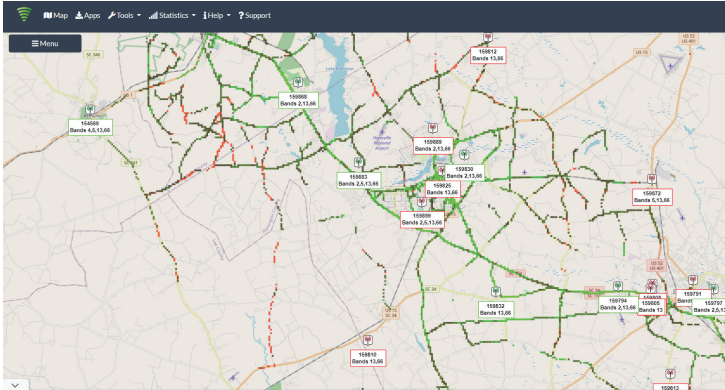

### 3.3 Determine the outdoor antenna's position

The outdoor antenna is usually placed at one of the 4 ends of the roof. Please choose the position according to the tower's location.

Make sure there are no barriers between the antenna and the tower.

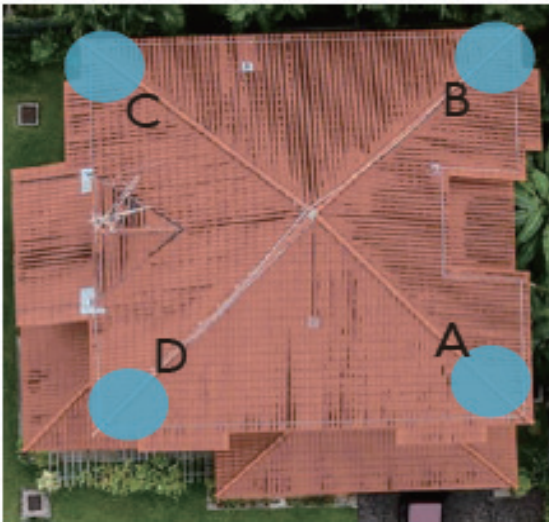

## Step 4 Install the outdoor antenna

### 4.1 Connect the outdoor antenna with the booster

- (1) Put the booster near to the location you would like to install in the future, or a place with power outlet temporarily.
- (2) Plug in the booster and make sure the Signal Supervisor app links with it smoothly.
- (3) Connect the booster with the outdoor antenna by the 49.2' cable.

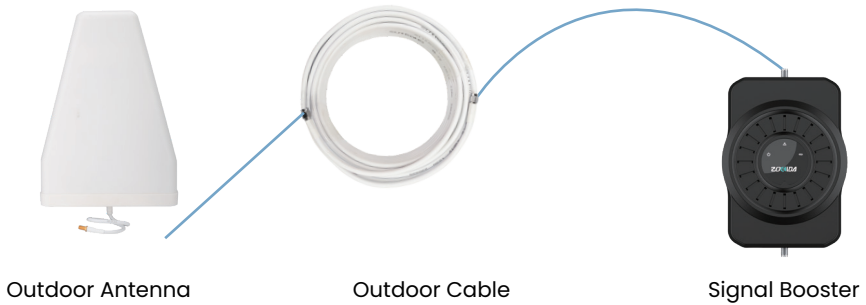

#### Notes:

- \*Please do NOT connect indoor antenna at this moment as it will influence the outside signal finding.
- \*Please place the booster within 30ft to the possible installation location of outdoor antenna if Bluetooth connection is applied. This is to ensure the App can connect to the booster.



## 4.2 Adjust and fix the Outdoor Antenna

Have your outdoor antenna pointed to the cell tower you found before and observe the reading on the app. Adjust the outdoor antenna accordingly.

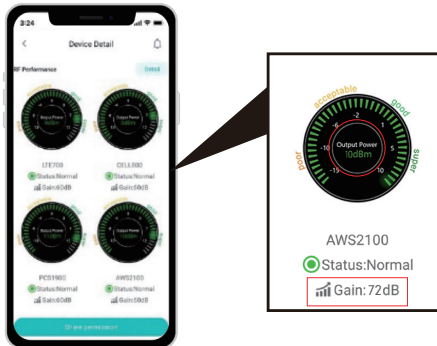

Notes:

- (1) The output power should be the higher the better.
- (2) The full output power for Ace 5S is 10dBm. And the full gain is 72dB.

### Professional Tips

- Keep in mind that it is normal for the output values may vary dynamically between 1-3 dB
- To optimize the signal for one carrier, point the outdoor antenna towards the closest cell phone tower designated to that carrier
- To optimize the signal for more than one carrier, point the outdoor antenna between multiple towers
- Make sure to slowly turn the antenna while taking the readings so the booster has time to adjust the reading
- Test and install the antenna at the same height where power outputs and gain values reach the booster's maximum capacity
- If you can't get a good output power, for instance, the value is below POOR level, it is highly likely that the installation will fail. Please either find a new place with better signal or drop the installation.

### 4.3 Install the outdoor antenna firmly

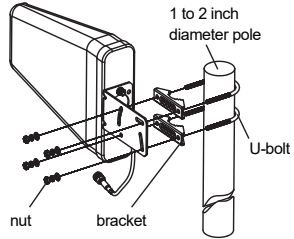
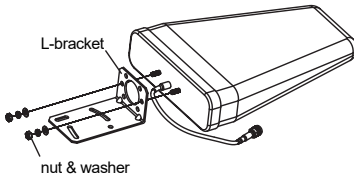

### 4.4 Reconfirm that the signal on signal gauge is the best!

Please **do take following screen shot** for future comparison during indoor antenna install.

What you are going to be paying attention to here, is the gain values. If you have interference between your indoor and outdoor antennas, then the booster will lower the gain and these values will decrease.

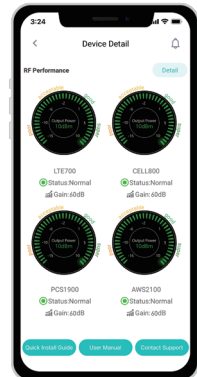

## Step 5: Install the indoor antenna

1) Connect the indoor antenna with the booster

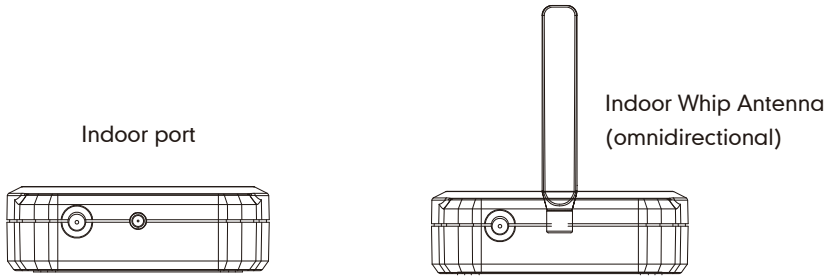

Connect the whip antenna to the Indoor port, and 13 feet lower in elevation, 30 feet separation between indoor whip antenna and outdoor antenna horizontally. (Put the booster where you would like to cover with signal.)

2) Install the indoor antenna

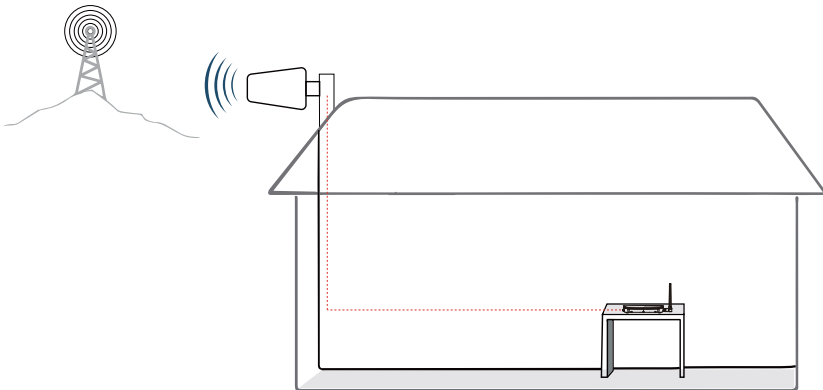

Put the signal booster on a dry and cool desktop, and it shall be easily accessible for maintenance.  
(As the whip antenna is a kind of omni antenna, it is suggested that the booster should be placed on a desk in the center of the area you would like to cover, rather than on a wall)

### 3) Adjust the position of the indoor antenna

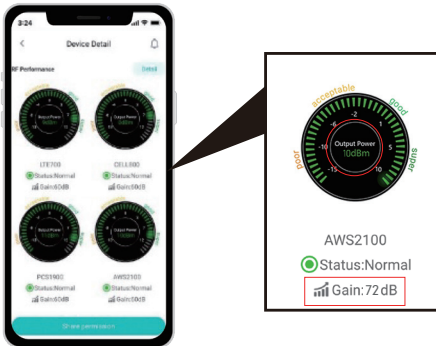

#### Note:

Make sure that the gain approaches 72dB. If not, please increase the vertical and horizontal distance between the two antennas or add some barriers.

#### Tips to avoid the Self-oscillation

1. Increase the distance between the outdoor and indoor antennas
2. Use barriers between the indoor and outdoor antennas

### 4) Signal quality test

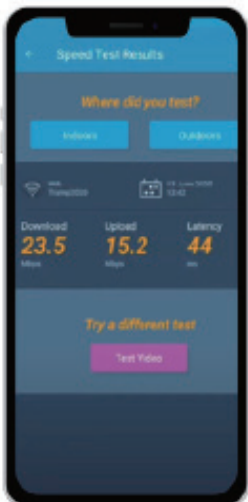

You could do the following:

- (1) First make sure the signal gauge value is unchanged from that during the outdoor antenna installation.
- (2) Do speed tests with the booster on and off, and make a comparison.
- (3) Check if the number of signal bars increases.
- (4) Make a phone call or send messages and check if the voice and streaming are better.

## Step 6: Install the booster and the cables

Based on personal need for coverage area, simply place the signal booster on the table, please make sure the booster is within the coverage area or mount the signal booster on a dry and cool area, and it shall be easily accessible for maintenance.

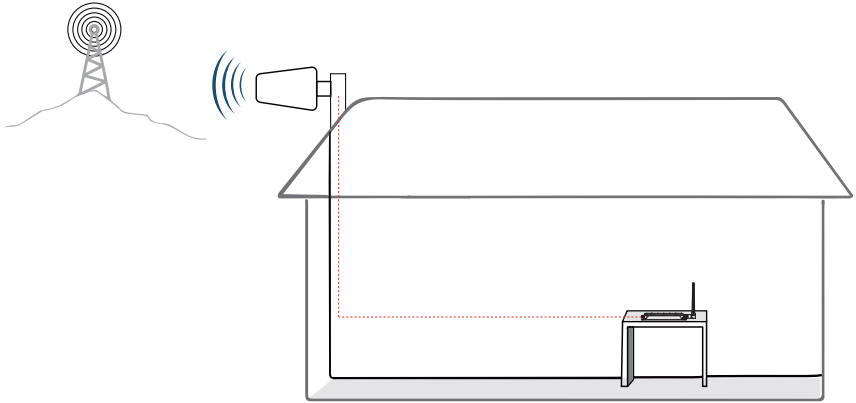

### Test again the performance after installation is done

- First make sure the Signal gauge value is unchanged from the outdoor antenna install.
- Test by a third-party app, calls and network data is smooth in most indoor signal coverage areas.

Now everything is completed and please start to enjoy the mobile services.

If the result is not satisfactory or you want to be better, you may repeat the whole or part of the process to improve.

Please contact us: Signal Supervisor app online support, Phone and Email in case you have any problems.

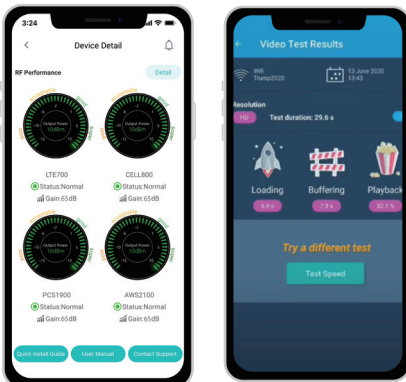

# Quick Troubleshooting Guide

If the booster is working normally, no further adjustment is required

OVERLOAD					
	DL GAIN	OUTPUT POWER	LED LIGHT PATTERN	REASON	SOLUTION
LTE700	<60dB	>=10dBm	Alarm light flashing and Power light solid blue	Outdoor signal is too strong	Have your outdoor antenna pointed slightly away from the cell tower
CELL800	<60dB	>=10dBm			
PCS1900	<60dB	>=10dBm			
AWS2100	<60dB	>=10dBm			

SELF-OSCILLATION					
	DL GAIN	OUTPUT POWER	LED LIGHT PATTERN	REASON	SOLUTION
LTE700	<60dB	<10dBm	Alarm light flashing blue (slight self-oscillation) or red (strong self-oscillation)	Inadequate separation of the indoor and outdoor antennas	<ol style="list-style-type: none"> <li>1. Increase vertical and horizontal distance between the outdoor and indoor antenna(s).</li> <li>2. Add barriers(e.g. walls)</li> </ol>
CELL800	<60dB	<10dBm			
PCS1900	<60dB	<10dBm			
AWS2100	<60dB	<10dBm			

POOR SIGNAL					
	DL GAIN	OUTPUT POWER	LED LIGHT PATTERN	REASON	SOLUTION
LTE700	>=60dB	-/-NEGATIVE	Alarm light OFF and power light solid blue	Input signal is too weak	<ol style="list-style-type: none"> <li>1. Try adjusting the outdoor antenna to the best direction</li> <li>2. Try adjusting the outdoor antenna to another cell tower</li> <li>3. Try increasing the height of the outdoor antenna and make sure there are no barriers between the tower and the outdoor antenna</li> </ol> Please try these solutions until the output power reaches or is over -5dBm.
CELL800	>=60dB	-/-NEGATIVE			
PCS1900	>=60dB	-/-NEGATIVE			
AWS2100	>=60dB	-/-NEGATIVE			

Normal but No Boosted Signal					
	DL GAIN	OUTPUT POWER	LED LIGHT PATTERN	REASON	SOLUTION
LTE700	>=60dB	>=-5dBm	Alarm light OFF and power light solid blue	1. The band is not supported 2. The Signal is from other Carriers	Check the band you are using again. If it stays at band66, get into the 'detail'/'Setting' of gagues on Signal Supervisor and switch off RF switch of AWS2100, then adjust the outdoor antenna again. It would be better if there are two persons and one can stay near the indoor antenna to check if the signal is boosted.
CELL800	>=60dB	>=-5dBm			
PCS1900	>=60dB	>=-5dBm			
AWS2100	>=60dB	>=-5dBm			

NORMAL					
	DL GAIN	OUTPUT POWER	LED LIGHT PATTERN	REASON	SOLUTION
LTE700	>=60dB	>=-5dBm	Alarm light OFF and power light solid blue		
CELL800	>=60dB	>=-5dBm			
PCS1900	>=60dB	>=-5dBm			
AWS2100	>=60dB	>=-5dBm			

**Note:**

Some customers have some misunderstandings about boosters, and we would like to clarify it here:

If you can't even get a stable 1 bar outside the house or on the roof, then we suggest you return it as it won't work in areas with very weak signal, the same is true of all boosters on the market.

# Technical Specifications

Model No.	Ace 5S
Working Band	Band 5 Band 12/17 Band 13 Band 2 Band 4
UL Frequency Range(MHz)	824-849/698-716/776-787/1850-1910/1710-1755
DL Frequency Range(MHz)	869-894/728-746/746-757/1930-1990/2110-2155
Supported Standards	CDMA, WCDMA, GSM, EDGE, HSPA+, EVDO, LTE, 5G and all cellular standar
Max. Gain	72 dB
Max. output power	UL 17 dBm,DL 10dBm
MGC (Step Attenuation )	≥ 31 dB / 1 dB step
I/O Port	SMA-Female
Impedance	50 ohm
Environment Conditions	IP40
Dimensions	150*100*40 mm / 5.9*3.9*1.6 in
Weight	1.76 lbs / 0.8 kg
Power Supply	Input AC100~240 V, 50/60 Hz, Output DC 12V / 1-1.5A

Notes: Support 5G only that's been or will be deployed in current 4G by DSS (Dynamic Spectrum Sharing) by carriers.

If there are any issues while installing a Zorida cell phone signal booster, please contact the technical support team through the following channels:

**Online Support:** Create a ticket or chat via Signal Supervisor App

 (972) 870-5666 (M-F from 9 am – 5 pm CST)

 [service@zorida.com](mailto:service@zorida.com)



# Authorized Accessories List

## Outdoor Antenna & Cable Kit Options

Kit 9-5050 Yagi 9dbi Antenna & 50' 5D Cable	Kit 9-50400 Yagi 9dbi Antenna & 50' 400 Cable	Kit 7-7550 Panel 7dbi Antenna & 75' 5D Cable
Kit 11-100400 Yagi 11dbi Antenna & 100' 400 Cable	Kit 9-75400 Yagi 9dbi Antenna & 75' 400 Cable	Kit 7-10050 Panel 7dbi Antenna & 100' 5D Cable
Kit 11-7550 Yagi 11dbi Antenna & 75' 5D Cable	Kit 9-100400 Yagi 9dbi Antenna & 100' 400 Cable	Kit 5-30400 Omni 5dbi Antenna & 30' 400 Cable
Kit 11-100500 Yagi 11dbi Antenna & 100' 5D Cable	Kit 9-7550 Yagi 9dbi Antenna & 75' 5D Cable	Kit 5-3050 Omni 5dbi Antenna & 30' 5D Cable
Kit 10-3050 Panel 10dbi Antenna & 30' 5D Cable	Kit 9-10050 Yagi 9dbi Antenna & 100' 5D Cable	Kit 5-50400 Omni 5dbi Antenna & 50' 400 Cable
Kit 10-50400 Panel 10dbi Antenna & 50' 400 Cable	Kit 7-3050 Panel 7dbi Antenna & 30' 5D Cable	Kit 5-5050 Omni 5dbi Antenna & 50' 5D Cable
Kit 10-5050 Panel 10dbi Antenna & 50' 5D Cable	Kit 7-50400 Panel 7dbi Antenna & 50' 400 Cable	Kit 5-75400 Omni 5dbi Antenna & 75' 400 Cable
Kit 10-75400 Panel 10dbi Antenna & 75' 400 Cable	Kit 7-5050 Panel 7dbi Antenna & 50' 5D Cable	Kit 5-10400 Omni 5dbi Antenna & 100' 400 Cable
Kit 10-100400 Panel 10dbi Antenna & 100' 400 Cable	Kit 7-75400 Panel 7dbi Antenna & 75' 400 Cable	Kit 5-7550 Omni 5dbi Antenna & 75' 5D Cable
Kit 10-7550 Panel 10dbi Antenna & 75' 5D Cable	Kit 7-100400 Panel 7dbi Antenna & 100' 400 Cable	Kit 5-10050 Omni 5dbi Antenna & 100' 5D Cable
Kit 10-10050 Panel 10dbi Antenna & 100' 5D Cable		

## Indoor Antenna & Cable Kit Options

Kit 72-5050-50 2 Panel 7dbi Antenna with 50' 5D N male & 2-Way Splitter	Kit 73-7550-50 3 Panel 7dbi Antenna & 75' 5D Cable & 3-Way Splitter	Kit 3-30400 Omni 3dBi Antenna with 30' 400 Cable
Kit 52-5050-50 2 Whip 5dbi Antenna & 50' 5D Cable & 2-Way Splitter	Kit 74-7550-50 4 Panel 7dbi Antenna & 75' 5D Cable & 3 2-Way Splitter	Kit 3-50400 Omni 3dBi Antenna & 50' 400 Cable
Kit 102-5050-50 2 Panel 10dbi Antenna with 50' 5D N male & 2-Way Splitter	Kit 3-30400 Omni 3dBi Antenna with 30' 400 Cable	Kit 32-50400-50 2 Omni 3dBi Antenna & 50' 400 Cable & 2-Way Splitter
Kit 103-7550-50 3 Panel 10dbi Antenna & 75' 5D Cable & 3-Way Splitter	Kit 3-5050 Omni 3dBi Antenna & 50' 5D Cable	Kit 33-50400-50 3 Omni 3dBi Antenna & 50' 400 Cable & 3-Way Splitter
Kit 104-7550-50 4 Panel 10dbi Antenna & 75' 5D Cable & 3 2-Way Splitter	Kit 3-7550 Omni 3dBi Antenna & 75' 5D Cable	Kit 34-50400-50 4 Omni 3dBi Antenna & 50' 400 Cable & 3 2-Way Splitter
	Kit 3-10050 Omni 3dBi Antenna & 100' 5D Cable	

Notes: Unauthorized use of accessories (power supplies, antennas, cables, etc.) is strictly prohibited.

# FCC and IC Statements

## **FCC RF EXPOSURE STATEMENT**

This equipment complies with FCC radiation exposure limits set forth for an uncontrolled environment. End users must follow the specific operating instruction for satisfying RF exposure compliance. This transmitter must not be colocated or operating in conjunction with any other antenna or transmitter.

## **IC RF EXPOSURE STATEMENT**

The device is in compliance with RF exposure limits. The minimum distance from body to use the device is 20 CM.

Le présent appareil est conforme aux normes de conformité ou aux limites d'intensité de champ RF. La distance minimale du corps à utiliser le dispositif est de 20 CM.

This equipment has been tested and found to comply with the limits for a Class B digital device, pursuant to part 15 of the FCC Rules. These limits are designed to provide reasonable protection against harmful interference in a residential installation. This equipment generates, uses and can radiate radio frequency energy and, if not installed and used in accordance with the instructions, may cause harmful interference to radio communications. However, there is no guarantee that interference will not occur in a particular installation. If this equipment does cause harmful interference to radio or television reception, which can be determined by turning the equipment off and on, the user is encouraged to try to correct the interference by one or more of the following measures:

- Re-orient or relocate the receiving antenna.
- Increase the separation between the equipment and receiver.
- Connect the equipment into an outlet on a circuit different from that to which the receiver is connected.
- Consult the dealer or an experienced radio/TV technician for help.

Changes or modifications not expressly approved by Zorida could void the user's authority to operate the equipment. For a complete list of antennas and cables approved for use with these boosters see Authorized Kitting Options.

**FCC 27.50(d)(4) Statement:** Fixed, mobile, and portable (handheld) stations operating in the 1710-1755 MHz band are limited to 1-watt EIRP. Fixed stations operating in the 1710-1755 MHz band are limited to a maximum antenna height of 10 meters above ground.

#### **FURTHER INFORMATION ON SIGNAL BOOSTER END-USE REGISTRATION**

The following links are the currently active contacts for booster registration with U.S. wireless providers:

<https://www.uscellular.com/uscellular/support/fcc-booster-registration.jsp>

[https://www.sprint.com/legal/fcc\\_boosters.html](https://www.sprint.com/legal/fcc_boosters.html)

<https://www.verizonwireless.com/solutions-and-services/accessories/register-signal-booster/> <https://support.t-mobile.com/docs/DOC-9827>

<https://securec45.securewebsession.com/attsignalbooster.com/>

**IC Statement:** This device complies with Innovation, Science and Economic Development Canada ICES-003 Compliance Label: CAN ICES-3 (B)/NMB-3(B). Le présent appareil est conforme Innovation, science et développement économique Canada ICES-003 Étiquette de conformité: CAN ICES-3 (B) / NMB-3 (B).

Please follow the link to access the CPC-2-1-05:

#### **This is a CONSUMER device.**

**BEFORE USE**, you **MUST REGISTER THIS DEVICE** with your wireless provider and have your provider's consent. Most wireless providers consent to the use of signal boosters. Some providers may not consent to the use of this device on their network. If you are unsure, contact your provider.

In Canada, **BEFORE USE**, you must meet all requirements set out in ISED CPC-2-1-05.

You **MUST** operate this device with approved antennas and cables as specified by the manufacturer. Antennas **MUST** be installed least 20 cm (8 inches) from (i. e., **MUST NOT** be installed within 20 cm of) any person.

You **MUST** cease operating this device immediately if requested by the FCC (or ISED in Canada) or a licensed wireless service provider.

**WARNING.** E911 location information may not be provided or may be inaccurate for calls served by using this device.

This device may be operated **ONLY** in a fixed location (i.e., may operate in a fixed location only) for in-building use.

## Return and Warranty Policies

**30-Day Money-Back Guarantee:** If for any reason the performance of any product is not acceptable, the product may be returned to the reseller within 30-days with proof of purchase. Please contact the customer support team.

**3-Year Warranty:** Signal boosters and kits are warranted for 3 years. We will repair or replace the unit and will cover the cost of delivery back to consumers located within the continental US and Canada. We will only cover shipping to our office if the booster was delivered to you recently, and was delivered defective. Damage caused by the use of non-company power supplies or other accessories is not covered under warranty.

Customers can choose to return the signal boosters and kits directly to the manufacturer at the purchaser's expense with a dated proof of purchase and a Returned Material Authorization (RMA) number supplied by us. RMA numbers may be obtained by contacting customer support at 972-870- 5666 or [service@zorida.com](mailto:service@zorida.com)

This warranty does not apply to any signal boosters or kits determined by us to have been subjected to tampering, misuse, abuse, neglect, or mishandling that alters or damages physical or electronic properties.

We are not liable for any Signal Supervisor application network connectivity issues. The cell phone signal booster relies on a strong, continuous and reliable connection to the internet in order to communicate with the cell phone application. For all Signal Supervisor Application related issues, please check your network strength and call our technical support.

Failure to use a surge-protected AC power strip with at least a 1000 Joule rating will void your warranty. Damage caused by lightning is not covered by this warranty.

All of the products that are packaged with other accessory products are intended for resale and used as a single integrated system. Such product kits are required to be sold to the end-users or subsequent reseller as packaged.